

## FM Radio Module LCD Display DIY Kit

### 1.Introduction:

It is a FM Radio Module Adjustable Wireless Receiver with LCD Display DC 3.7V 0.5W 8ohm Speaker. It can receiving FM station, display time, set alarm clock(the alarm is FM audio). User also can set receiving frequency as universal frequency 87MHz ~ 108.6MHz or campus broadcast frequency 72MHz ~ 92MHz or aviation frequency 110MHz ~ 130MHz.

### 2.Feature:

- 1>.Universal frequency 87MHz ~ 108.6MHz
- 2>.Campus broadcast frequency 72MHz ~ 92MHz
- 3>.Aviation frequency 110MHz ~ 130MHz
- 4>.FM Alarm clock timing play function
- 5>.Adjustable FM stations and volume
- 6>.HD LCD display
- 7>.DIY manual soldering
- 8>.Simple and easy to operate

### 3.Parameter:

- 1>.Item name: FM Radio Module LCD Display DIY Kit
- 2>.Work Voltage:DC 3V
- 3>.Amplifier Power:0.5W
- 4>.Work Temperature:-40℃~85℃
- 5>.Work Humidity:0%~95%RH
- 6>.Size(Installed):120\*75\*25mm

### 4.Button Description:

- 1>.POWER ON/OFF : It is used to switch FM and Time.
- 2>.AL ON/OFF : It is used to turn ON or OFF alarm function. It turns on the alarm function if there is a wireless symbol on LCD screen at the first line.
- 3>.MINset : It is used to change value for minutes. It supports press once or keep press. Note: Its value can only increase, not decrease.The minutes value reaches the maximum value(59) and then increases form 0 again. Pay attention to AM and PM on LCD screen at the first line.
- 4>.HEset : It is used to change value for hours. It supports press once or keep press. Note: Its value can only increase, not decrease.The hours value reaches the maximum value(12) and then increases form 0 again.Pay attention to AM and PM on LCD screen at the first line.
- 5>.TIMEset : It is used to enter set time mode. It is recommended to press and

hold this button first and then press 'HEset' and 'MINset' to calibrate the RTC time.

6>.ALdisp : It is used to enter set alarm mode. It is recommended to press and hold this button first and then press 'HEset' and 'MINset' to set alarm time. It will display alarm time by press 'ALdisp' at any time.

## 5.Set Parameters:

1>.Calibrate display time:

1.1>.Make sure the screen displaying time by press 'POWER ON/OFF' button.

1.2>.Press 'TIMEset' button and keep press.

1.3>.Press or keep press 'HEset' button to change hour value.

1.4>.Press or keep press 'MINset' button to change minute value.

2>.Set alarm time:

2.1>.Press 'AL ON/OFF' button to turn ON alarm function.

2.2>.Press 'ALdisp' button and keep press. There is a bell symbol in the upper right corner.

2.3>.Press or keep press 'HEset' button to change hour value.

2.4>.Press or keep press 'MINset' button to change minute value.

2.5>.It will display alarm time by press 'ALdisp' at any time.

3>.Select the gear on the right to switch the FM station.

4>.Select the gear on the left to change the volume.

## 6.Component listing:

NO.	Component Name	PCB Marker	Parameter	QTY
1	Metal Film Resistor	R7,R8	10ohm	2
2	Metal Film Resistor	R1	100ohm	1
3	Metal Film Resistor	R4,R10	330ohm	2
4	Metal Film Resistor	R2	560ohm	1
5	Metal Film Resistor	R5,R6,R9	10Kohm	3
6	Metal Film Resistor	R3	150Kohm	1
7	CD2003GP	IC1	DIP-16	1
8	TDA2822A	IC2	DIP-8	1
9	Ceramic Capacitor	C10	2pF	1
10	Ceramic Capacitor	C3-C6	30pF	4
11	Ceramic Capacitor	C7	82pF	1
12	Ceramic Capacitor	C14	0.02uF 202	1
13	Ceramic Capacitor	C11,C12	0.47uF 472	2
14	Ceramic Capacitor	C8,C9,C13,C15,C17	0.1uF 104	5
15	Electrolytic Capacitor	C16	10uF	1
16	Electrolytic Capacitor	C18-C20	470uF	3

17	CMB444HE Capacitor	C1,C1-1,C2,C2-1		1
18	S9018 Transistor	Q1	TO-92	1
19	S8550 Transistor	Q2	TO-92	1
20	5.5T Coil Inductor	L1	5.5T	1
21	6.5T Coil Inductor	L2,L3	6.5T	2
22	Ceramic Filter	CF1	L10.7A	1
23	Frequency Discriminator	CF2	J10.7C	1
24	Potentiometer	RV	50Kohm	1
25	AUX Audio Socket	EJ	3.5mm	1
26	Self-locking Switch	SW	8*8mm	1
27	Switch Cap	SW		1
28	Audio Adjust Gear			1
29	Black Button Set		5-Button	1
30	Metal Button Sheet		D2.5mm	5
31	Battery Positive Metal Sheet			1
32	Battery Negative Metal Sheet			1
33	Antenna Connect Metal Sheet			1
34	Antenna		10-35cm	1
35	8ohm 0.5W Speaker		D57mm	1
36	LCD Display Module		68*52*8mm	1
37	M2*8mm Screw			1
38	M2*5mm Screw			10
39	M1.7*3.8mm Screw(for CMB444HE)			1
40	M2.5*5mm Screw(for Antenna)			1
41	5Pin Connect Wire		60mm	1
42	Gray Antenna Connect Wire		120mm	1
43	Power Supply Wire		80mm	2
44	Speaker Wire		60mm	2
45	Black Case with Battery Cover			2
46	PCB		114*48*1.2mm	1

Note:Users can complete the installation according to the PCB silk screen and component list.

## 7.Note:

- 1>.It is a DIY kit so that need finish install by user.
- 2>.It supports alarm clock but its alarm to play FM audio.
- 3>.Its receiving frequency range needs to be adjusted during installation.
- 4>.Its LCD will keep the display frequency or time,but can not be turn OFF.
- 5>.User needs to re-calibrate the time after the next battery installation.

## 8.Application:

- 1>.Training welding skills
- 2>.Student school
- 3>.DIY production
- 4>.Project Design
- 5>.Electronic competition
- 6>.Gift giving
- 7>.Crafts collection
- 8>.Home decoration
- 9>.Souvenir collection
- 10>.Graduation design
- 11>.Holiday gifts

## 9.Installation Tips:

- 1>.User needs to prepare the soldering tool at first.
- 2>.Please be patient until the installation is complete.
- 3>.The package is DIY kit.It need finish install by user.
- 4>.The soldering iron can't touch the components for a long time(1.0 second), otherwise it will damage the components.
- 5>.Pay attention to the positive and negative of the components.
- 6>.Strictly prohibit short circuit.
- 7>.Install complex components preferentially.
- 8>.Make sure all components are in right direction and right place.
- 9>.Please wear anti-static gloves or anti-static wristbands when installing electronic components.
- 10>.It is strongly recommended to read the installation manual before starting installation!!!

## 10.Installation Steps(Please be patient install!!!):

- 1>.Step 1: Install 2pcs 10ohm Metal Film Resistor at R7,R8. Identify the resistor value as shown in color: Brown/Black/Black/Golden/Brown.
- 2>.Step 2: Install 1pcs 100ohm Metal Film Resistor at R1. Identify the resistor value as shown in color: Brown/Black/Black/Black/Brown.
- 3>.Step 3: Install 2pcs 330ohm Metal Film Resistor at R4,R10. Identify the resistor value as shown in color: Brown/Brown/Black/Black/Brown.
- 4>.Step 4: Install 1pcs 560ohm Metal Film Resistor at R2. Identify the resistor value as shown in color: Green/Blue/Black/Black/Brown.
- 5>.Step 5: Install 3pcs 10Kohm Metal Film Resistor at R5,R6,R9. Identify the resistor value as shown in color: Brown/Black/Black/Red/Brown.
- 6>.Step 6: Install 1pcs 150Kohm Metal Film Resistor at R1. Identify the resistor value as shown in color: Brown/Green/Black/Orange/Brown.

7>.Step 7: Install 1pcs 2pF Ceramic Capacitor at C10.Pay attention to the screen printing on the surface of capacitor.

8>.Step 8: Install 4pcs 30pF Ceramic Capacitor at C3-C6.Pay attention to the screen printing on the surface of capacitor.

9>.Step 9: Install 1pcs 82pF Ceramic Capacitor at C7.Pay attention to the screen printing on the surface of capacitor.

10>.Step 10: Install 1pcs 0.02uF 202 Ceramic Capacitor at C14.Pay attention to the screen printing on the surface of capacitor.

11>.Step 11: Install 2pcs 0.47uF 472 Ceramic Capacitor at C11,C12.Pay attention to the screen printing on the surface of capacitor.

12>.Step 12: Install 5pcs 0.1uF 104 Ceramic Capacitor at C8,C9,C13,C15,C17. Pay attention to the screen printing on the surface of capacitor.

13>.Step 13: Install 1pcs DIP-16 IC CD2003GP at IC1.There is a mark(notch) on one end of the IC and there is a mark(curved silk screen printing) on PCB where the IC can place on.These two marks are corresponding to each other and are used to specify the installation direction of the IC.

14>.Step 14: Install 1pcs DIP-8 IC TDA2822A at IC2.There is a mark(notch) on one end of the IC and there is a mark(curved silk screen printing) on PCB where the IC can place on.These two marks are corresponding to each other and are used to specify the installation direction of the IC.

15>.Step 15: Install 1pcs TO-92 S9018 Transistor at Q1. Pay attention to the installation direction.Arc screen printing corresponds to arc case.

16>.Step 16: Install 1pcs TO-92 S8550 Transistor at Q2. Pay attention to the installation direction.Arc screen printing corresponds to arc case.

17>.Step 17: Install 1pcs 5.5T Coil Inductor at L1. Note: It is recommended that the distance between the coils be slightly enlarged in order to improve the receiving frequency range.

18>.Step 18: Install 2pcs 6.5T Coil Inductor at L2,L3.

19>.Step 19: Install 1pcs 3Pin L10.7A Ceramic Filter at CF1.It is no need to distinguish between positive and negative poles.

20>.Step 20: Install 1pcs 2Pin J10.7C Frequency Discriminator at CF2.It is no need to distinguish between positive and negative poles.

21>.Step 21: Install 1pcs 10uF Electrolytic Capacitor at C16. There is a white ' + ' on PCB silk screen printing where the positive(anode) can insert into.The longer lead is positive(anode)

22>.Step 22: Install 3pcs 470uF Electrolytic Capacitor at C18-C20. There is a white ' + ' on PCB silk screen printing where the positive(anode) can insert into.The longer lead is positive(anode). Note:Bend pin.

23>.Step 23: Install 1pcs 3.5mm AUX Audio Socket at EJ.

24>.Step 24: Install 1pcs 50Kohm Potentiometer at RV.

25>.Step 25: Install 1pcs CMB444HE Capacitor at C1,C1-1,C2,C2-1. Note: Larger pin insert larger pad.

26>.Step 26: Install 1pcs 8\*8mm Self-locking Switch at SW.

27>.Step 27: Fix 1pcs Audio Adjust Gear on CMB444HE Capacitor by 1pcs

M1.7\*3.8mm Screw(The smallest screw).

28>.Step 28: Connect 1pcs 80mm Red wire to B+ and 1pcs 80mm Black wire to B- as power supply wire.Note: The wires can be installed in the last step.

29>.Step 29: Connect 1pcs 120mm Gray Antenna Connect Wire at ANT as Antenna.

30>.Step 30: Connect 1pcs 60mm 5Pin Connect Wire on LCD Display Module.  
Note:The red wire connect to VCC.

31>.Step 31: Install 5pcs D2.5mm Metal Button Sheet on LCD Display Module as following tips:

31.1>.Prepare the insulating tape and cut it into about 7\*7mm pieces.

31.2>.Place Metal Sheet on pad.Note that the pins are placed in the 2 via.

31.3>.Press the metal sheet with tweezers.

31.4>.Stick the insulating tape along the edge.

31.5>.Note:please do not use tin to fix metal sheet.

32>.Step 32: Connect Main PCB and LCD Display Module. Note PCB silk screen that VCC connect to VCC on two PCB.

33>.Step 33: Fix 1pcs Antenna with 1pcs Metal Sheet by 1pcs M2.5\*5mm Screw.

34>.Step 34: Install Battery Positive/Negative Metal Sheet on Case.Pay attention to their installation position.

35>.Step 35: Connect 1pcs D57mm 8ohm 0.5W Speaker to SP1 and SP2 on Main PCB by 2pcs 60mm Wire.The speakers does not need to distinguish between positive and negative poles.

36>.Step 36: Install 1pcs Black Button Cap on Self-locking Switch.

37>.Step 37: Connect 120mm Gray Antenna Wire to Antenna Metal Sheet.

38>.Step 38: Connect 80mm Red wire to Positive Metal Sheet and connect 80mm Black wire to Negative Metal Sheet(with Spring).

39>.Step 39: Debugging frequency range.

39.1>.Install 2pcs AA battery(Not include).

39.2>.Counterclockwise rotation frequency regulator(Audio Adjust Gear on CMB444HE Capacitor) to so that the display shows the minimum frequency.

39.3>.Adjust the distance between the coils on 5.5T Coil Inductor on L1 if the LCD does not display 87MHz to make sure the LCD display 87MHz.

39.4>.Clockwise rotation frequency regulator(Audio Adjust Gear on CMB444HE Capacitor) to so that the display shows the maximum frequency.

39.5>.Adjust the potentiometer on C1-1 if the LCD does not display 108.6MHz to make sure the LCD display 108.6MHz.

39.6>.Adjust these two parameters repeatedly to make the final frequency range is 87MHz~108.6MHz.

39.7>.In case of noise, the L1 5.5T coil can be sealed with paraffin or hot melt adhesive after adjustment.

39.8>.The campus broadcast frequency range is 72MHz~92MHz.

39.9>.The frequency range of aviation frequency band is a 110MHz~130MHz (Note: It requires L1 5.5T to reduce one coil).

39.10>.It is recommended that the frequency setting range should not

exceed 20MHz.

40>.Step 40: Cut one black button from Black Button Set as shown. Don't be wrong!

41>.Step 41: The black button position is shown in the figure.

42>.Step 42: Fix LCD Display Module by 2pcs M2\*5mm Screw. Note:The other two holes are not fixed for the time being.

43>.Step 43: Sometimes user need to re-install the black power wire in order to install PCB conveniently.

44>.Step 44: Fix two case by 1pcs M2\*8mm Screw and 4pcs M2\*5mm Screw.

45>.Step 45: Install 2pcs AA battery to check whether it can play normally(Users need to prepare batteries by yourself).If there is a fault, it is recommended to check whether each component is installed correctly and whether the pad has false soldering and so on. Please contact us if you have any other questions.

## 11.Install shown steps:

Step 1: Install 2pcs 10ohm Metal Film Resistor at R7,R8. Identify the resistor value as shown in color: Brown/Black/Black/Golden/Brown.

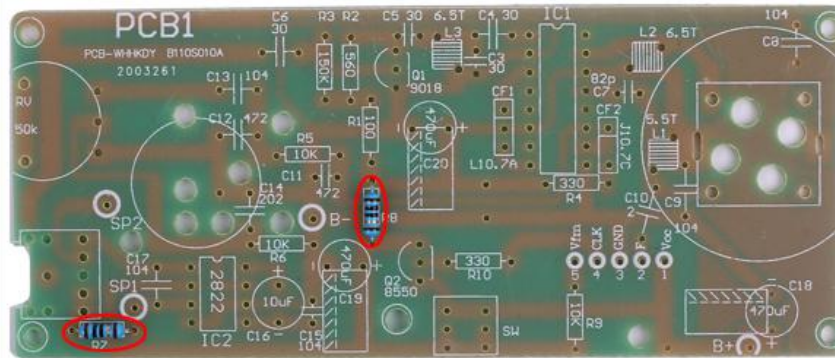

Step 2: Install 1pcs 100ohm Metal Film Resistor at R1. Identify the resistor value as shown in color: Brown/Black/Black/Black/Brown.

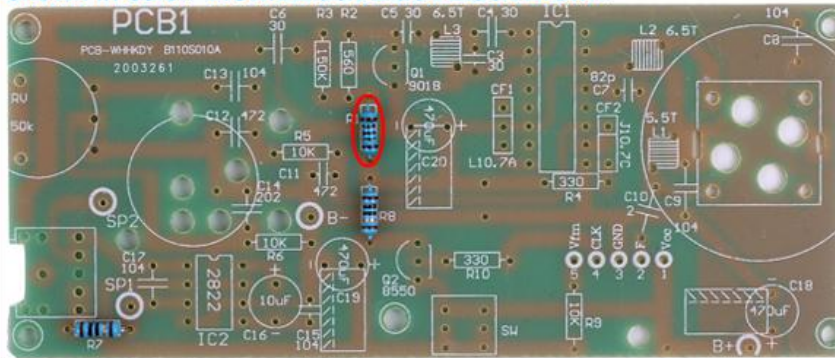

**Step 3: Install 2pcs 330ohm Metal Film Resistor at R4,R10. Identify the resistor value as shown in color: Brown/Brown/Black/Black/Brown.**

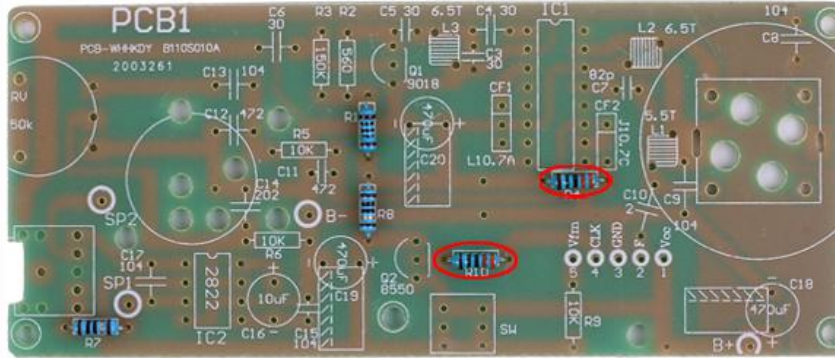

**Step 4: Install 1pcs 560ohm Metal Film Resistor at R2. Identify the resistor value as shown in color: Green/Blue/Black/Black/Brown.**

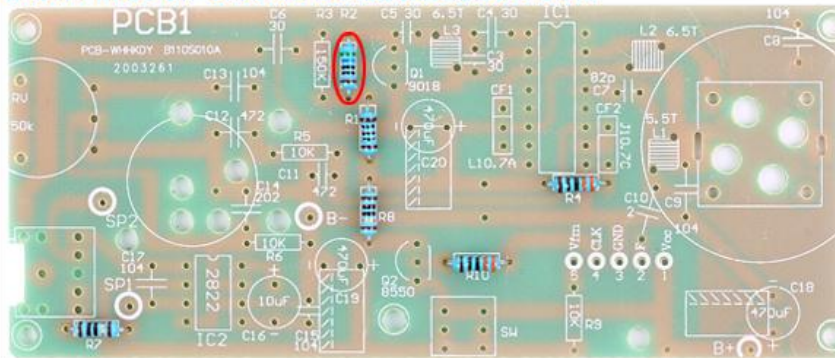

**Step 5: Install 3pcs 10Kohm Metal Film Resistor at R5,R6,R9. Identify the resistor value as shown in color: Brown/Black/Black/Red/Brown.**

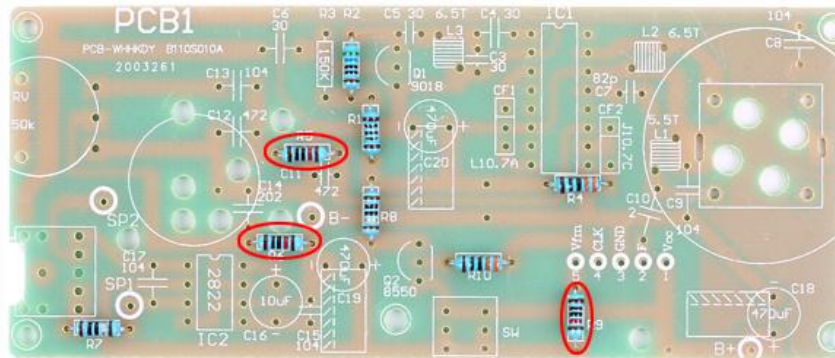

**Step 6: Install 1pcs 150Kohm Metal Film Resistor at R1. Identify the resistor value as shown in color: Brown/Green/Black/Orange/Brown.**

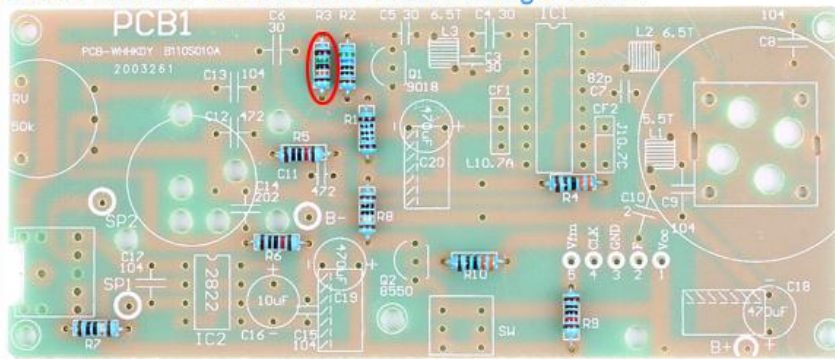



Step 7: Install 1pcs 2pF Ceramic Capacitor at C10. Pay attention to the screen printing on the surface of capacitor.

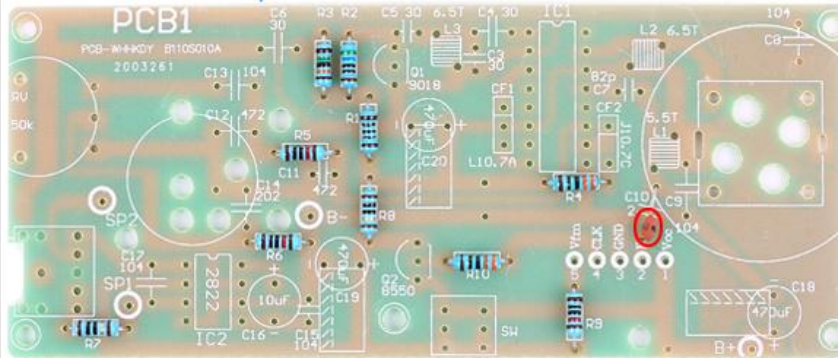

Step 8: Install 4pcs 30pF Ceramic Capacitor at C3-C6. Pay attention to the screen printing on the surface of capacitor.

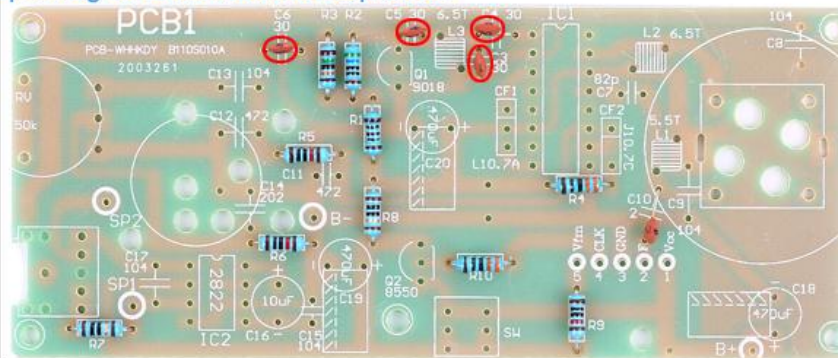

Step 9: Install 1pcs 82pF Ceramic Capacitor at C7. Pay attention to the screen printing on the surface of capacitor.

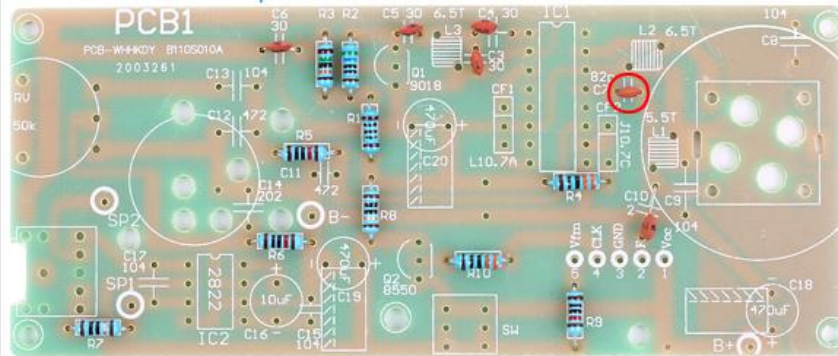

Step 10: Install 1pcs 0.02uF 202 Ceramic Capacitor at C14. Pay attention to the screen printing on the surface of capacitor.

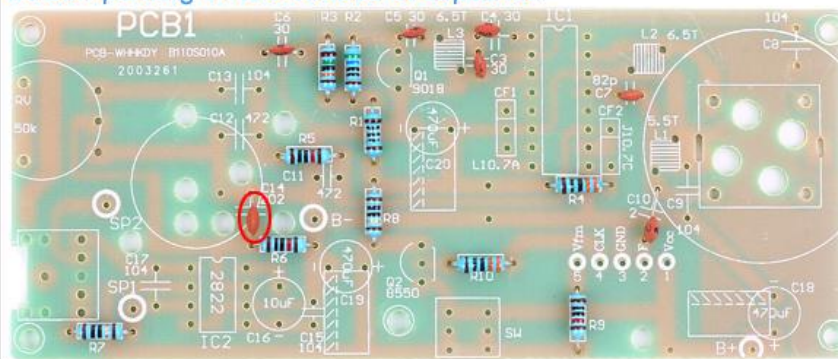

Step 11: Install 2pcs 0.47uF 472 Ceramic Capacitor at C11,C12. Pay attention to the screen printing on the surface of capacitor.

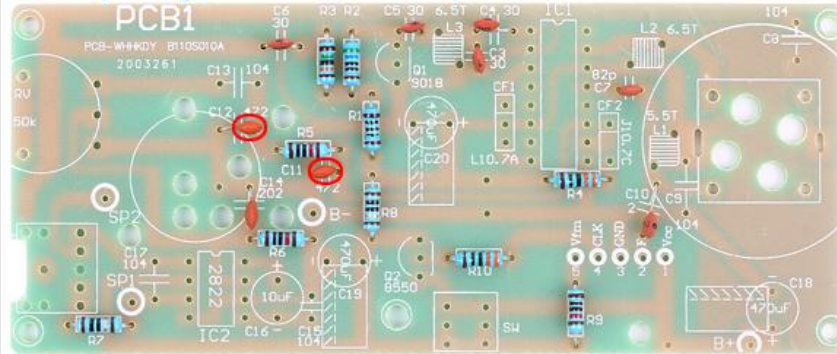

Step 12: Install 5pcs 0.1uF 104 Ceramic Capacitor at C8,C9,C13,C15,C17. Pay attention to the screen printing on the surface of capacitor.

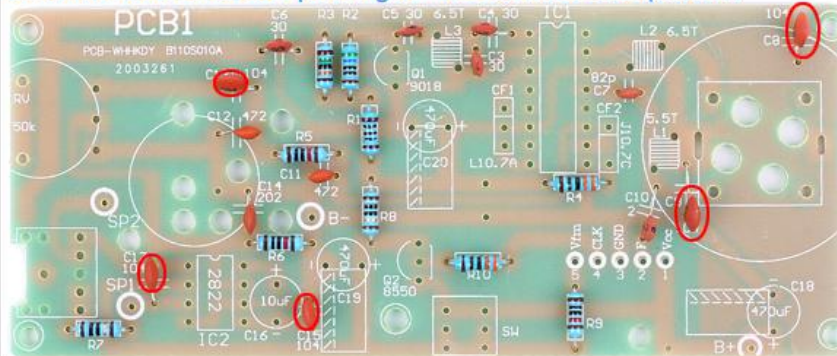

Step 13: Install 1pcs DIP-16 IC CD2003GP at IC1. There is a mark(notch) on one end of the IC and there is a mark(curved silk screen printing) on PCB where the IC can place on. These two marks are corresponding to each other and are used to specify the installation direction of the IC.

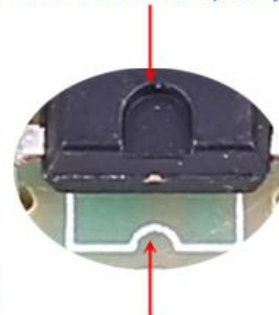
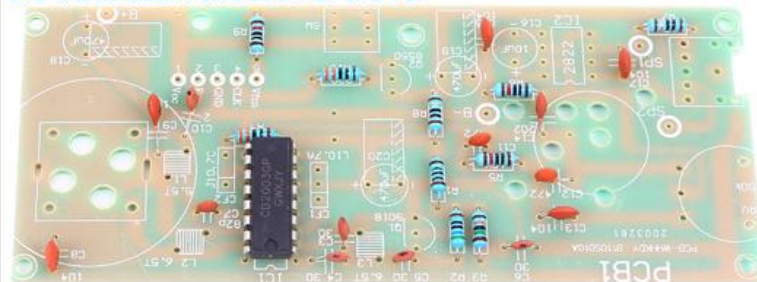

Step 14: Install 1pcs DIP-8 IC TDA2822A at IC2. There is a mark(notch) on one end of the IC and there is a mark(curved silk screen printing) on PCB where the IC can place on. These two marks are corresponding to each other and are used to specify the installation direction of the IC.

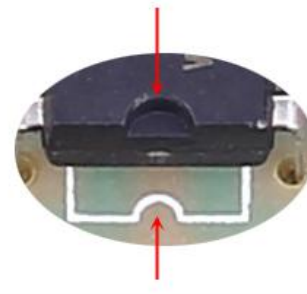
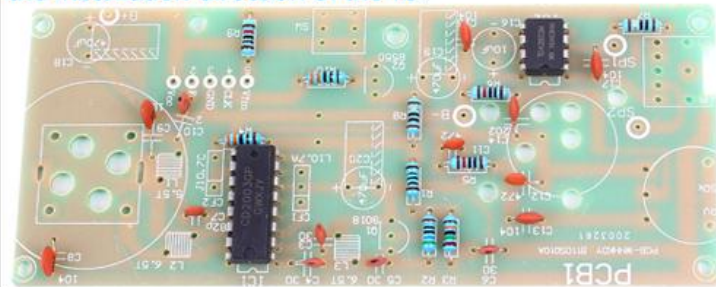

**Step 15: Install 1pcs TO-92 S9018 Transistor at Q1. Pay attention to the installation direction. Arc screen printing corresponds to arc case.**

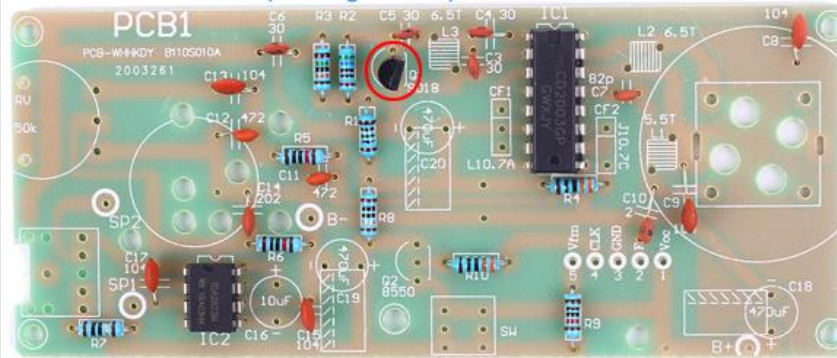

**Step 16: Install 1pcs TO-92 S8550 Transistor at Q2. Pay attention to the installation direction. Arc screen printing corresponds to arc case.**

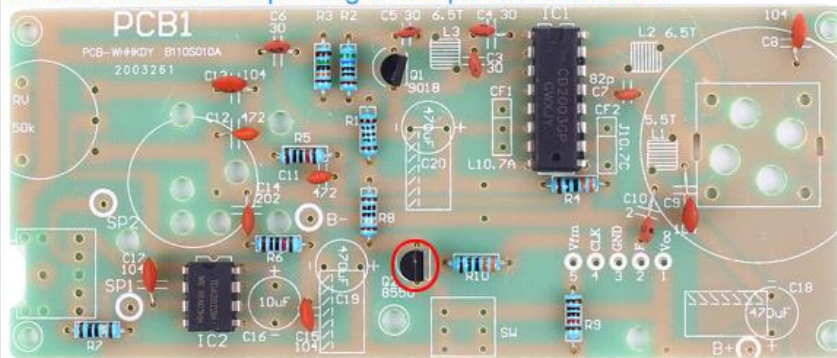

**Step 17: Install 1pcs 5.5T Coil Inductor at L1. Note: It's recommended that the distance between the coils be slightly enlarged in order to improve receiving frequency range.**

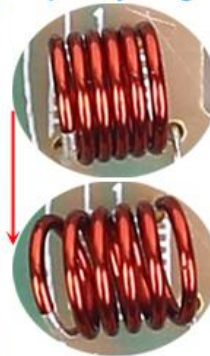
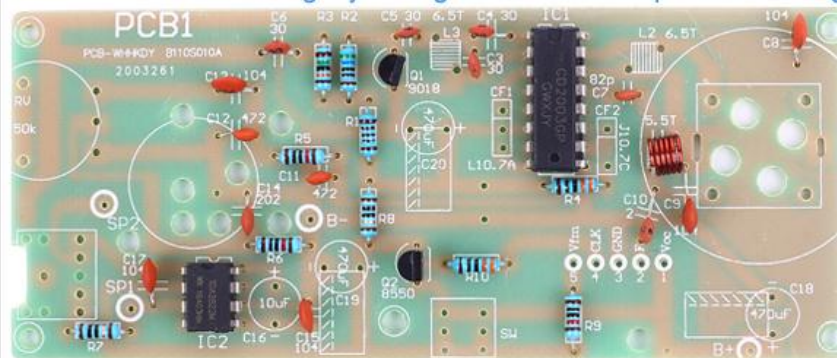

**Step 18: Install 2pcs 6.5T Coil Inductor at L2, L3.**

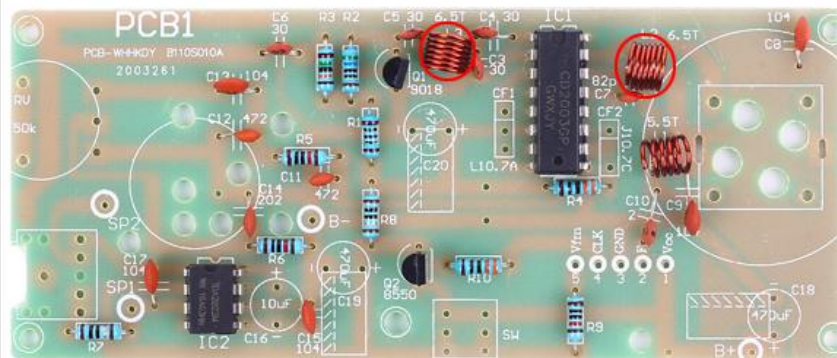

Step 19: Install 1pcs 3Pin L10.7A Ceramic Filter at CF1. It is no need to distinguish between positive and negative poles.

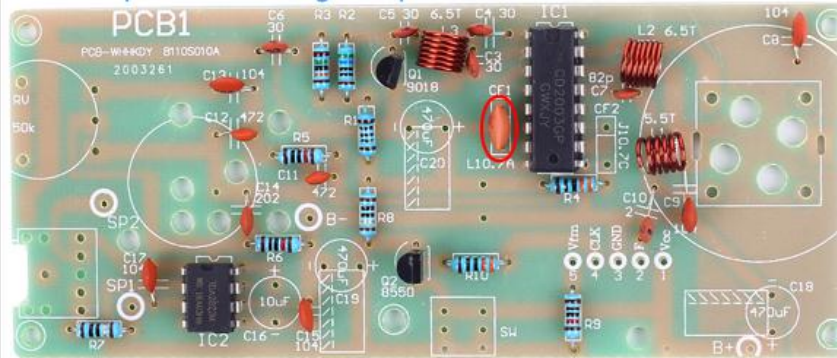

Step 20: Install 1pcs 2Pin J10.7C Frequency Discriminator at CF2. It is no need to distinguish between positive and negative poles.

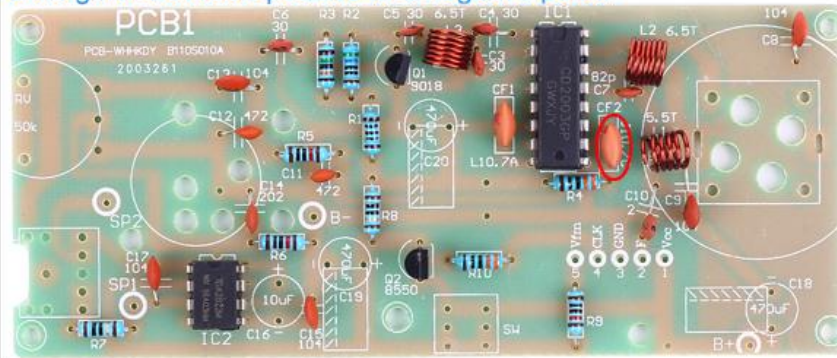

Step 21: Install 1pcs 10uF Electrolytic Capacitor at C16. There is a white '+' on PCB silk screen printing where positive(anode) can insert. Longer lead is positive(anode)

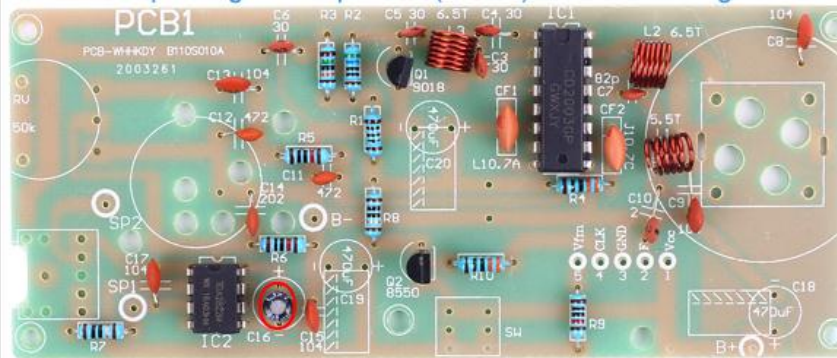

Step 22: Install 3pcs 470uF Electrolytic Capacitor at C18-C20. There is a white '+' on PCB silk screen printing where the positive(anode) can insert into. The longer lead is positive(anode). Note: Bend pin.

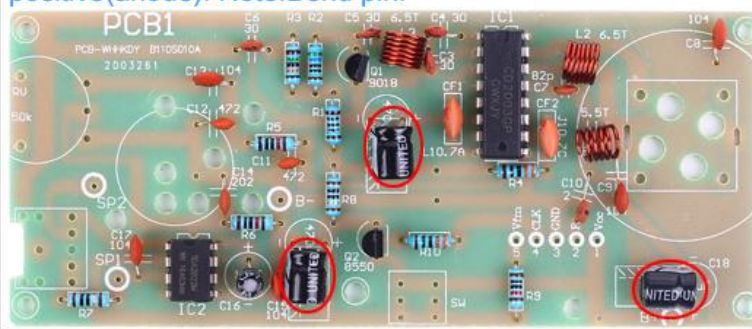

**Step 23: Install 1pcs 3.5mm AUX Audio Socket at EJ.**

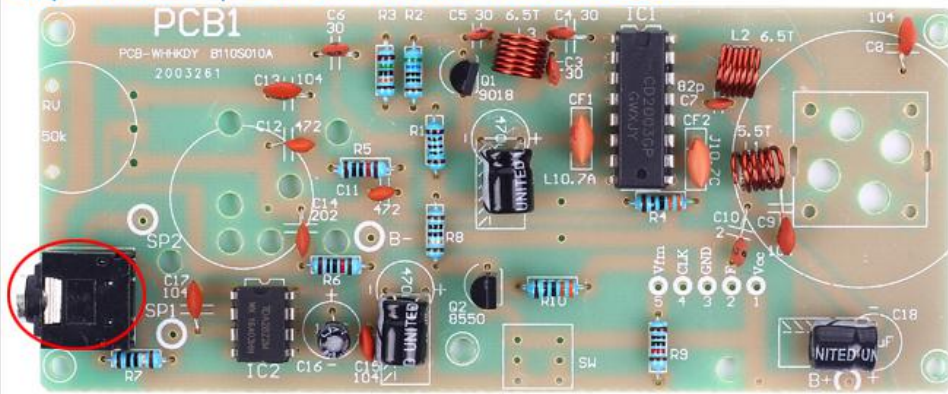

**Step 24: Install 1pcs 50Kohm Potentiometer at RV.**

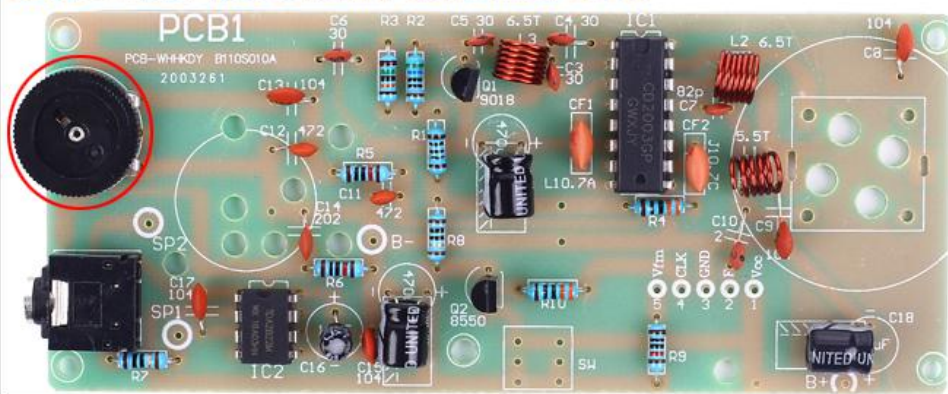

**Step 25: Install 1pcs CMB444HE Capacitor at C1,C1-1,C2,C2-1. Note: Larger pin insert larger pad.**

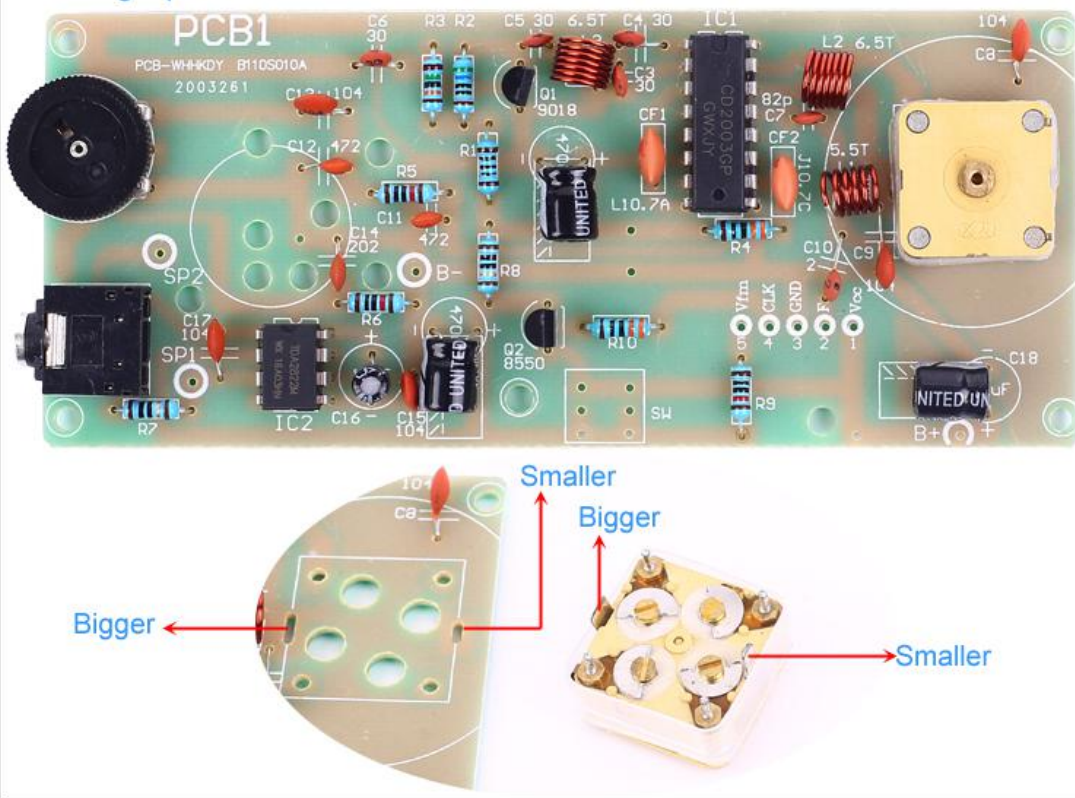

Step 26: Install 1pcs 8\*8mm Self-locking Switch at SW.

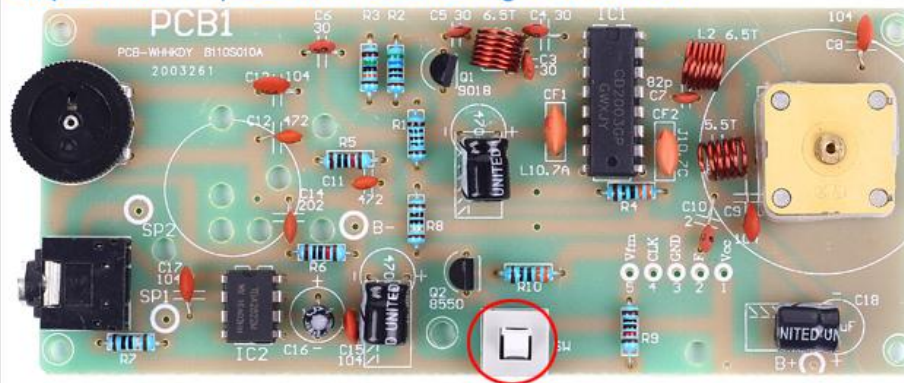

Step 27: Fix 1pcs Audio Adjust Gear on CMB444HE Capacitor by 1pcs M1.7\*3.8mm Screw(The smallest screw).



Step 28: Connect 1pcs 80mm Red wire to B+ and 1pcs 80mm Black wire to B- as power supply wire. Note: The wires can be inserted in the last step.

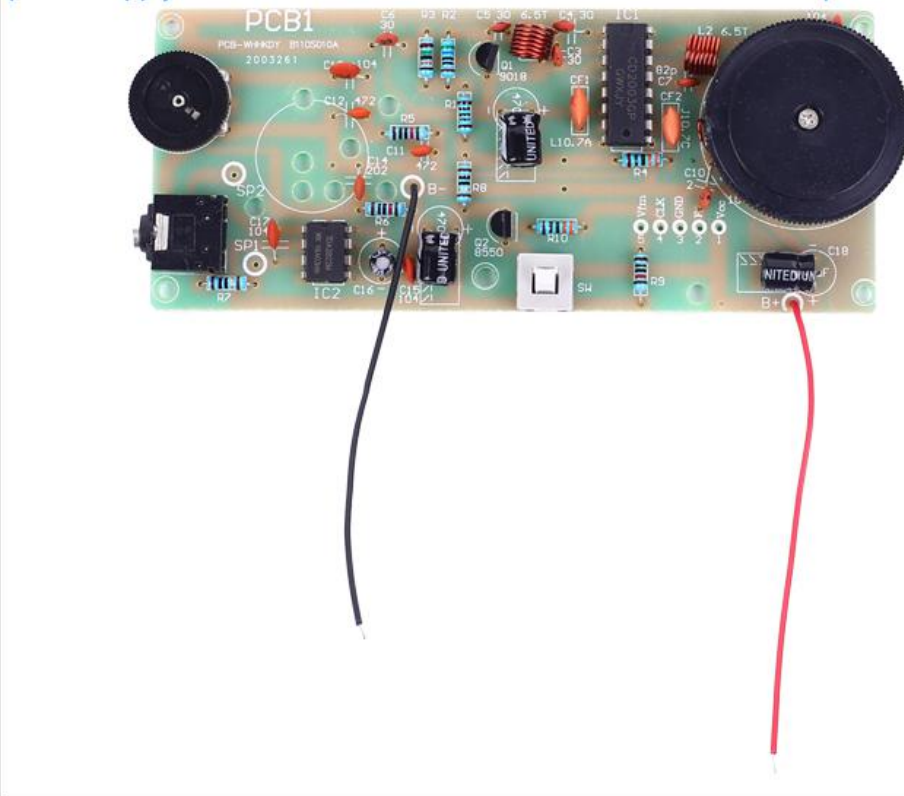

Step 29: Connect 1pcs 120mm Gray Antenna Connect Wire at ANT as Antenna.

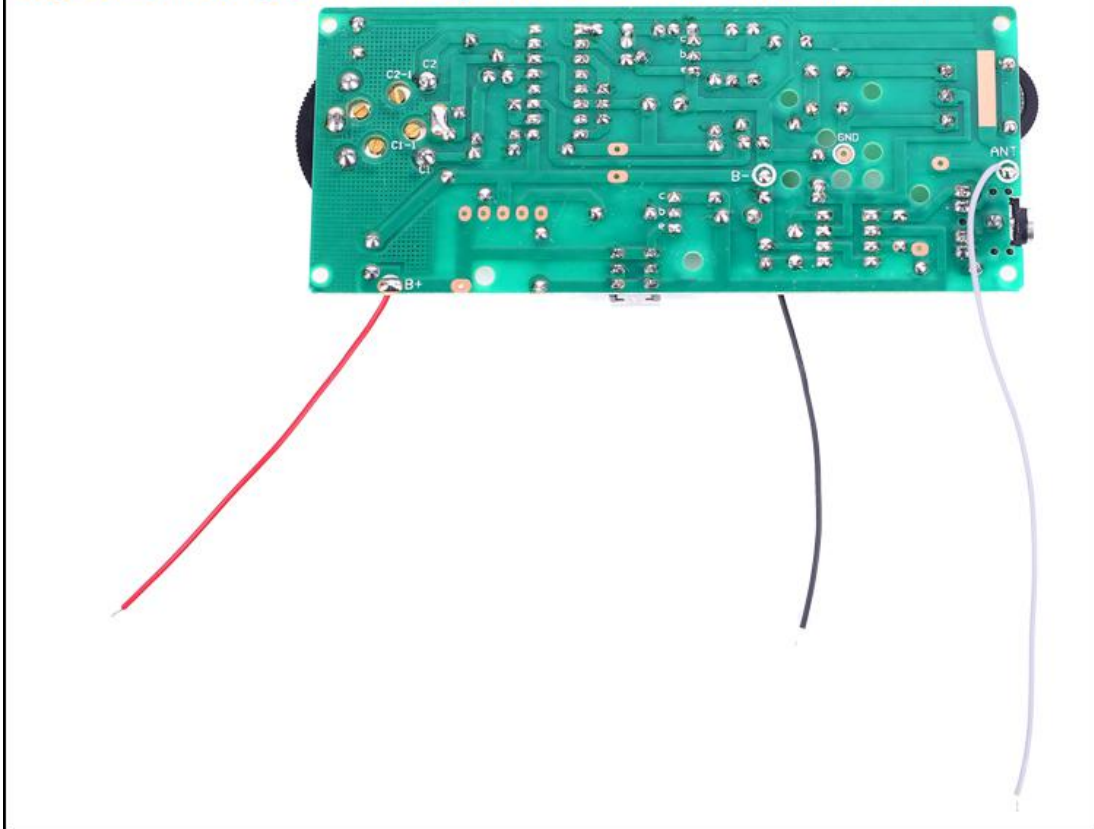

Step 30: Connect 1pcs 60mm 5Pin Connect Wire on LCD Display Module.  
Note: The red wire connect to VCC.

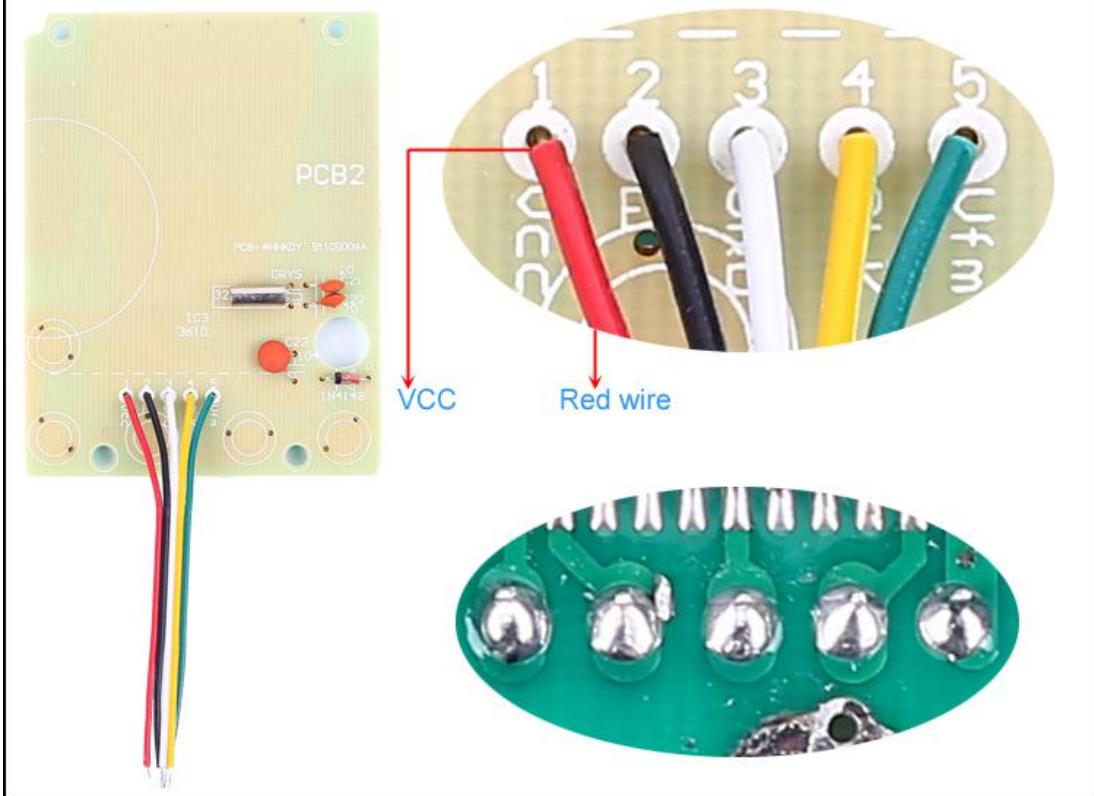

Step 31: Install 5pcs D2.5mm Metal Button Sheet on LCD Display Module as following tips:

- 31.1>.Prepare the insulating tape and cut it into about 7\*7mm pieces.
- 31.2>.Place Metal Sheet on pad.Note that the pins are placed in the 2 via.
- 31.3>.Press the metal sheet with tweezers.
- 31.4>.Stick the insulating tape along the edge.
- 31.5>.Note:please do not use tin to fix metal sheet.

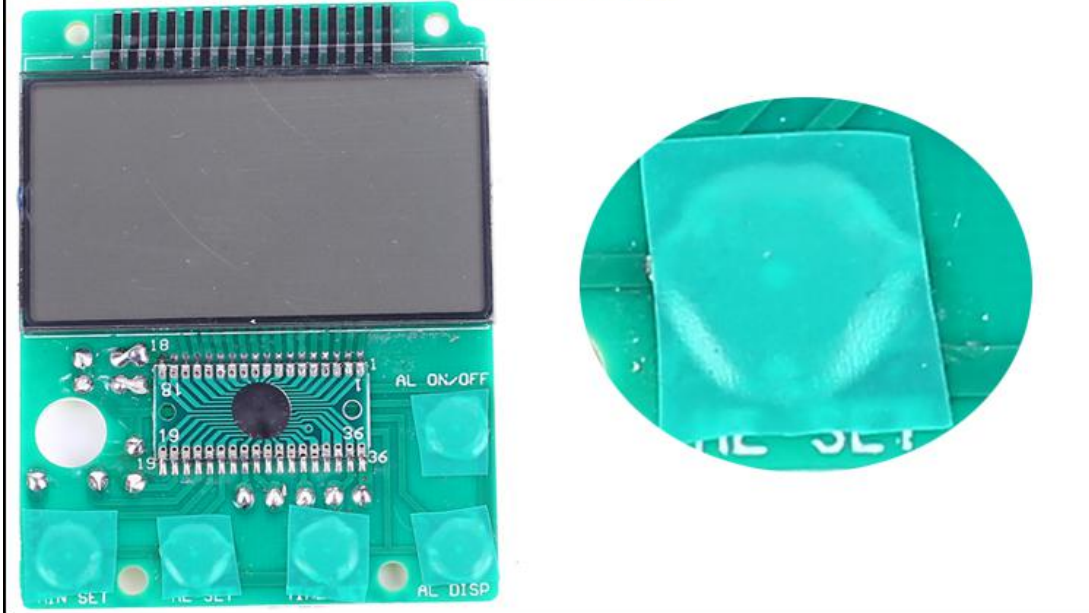

Step 32: Connect Main PCB and LCD Display Module. Note PCB silk screen that VCC connect to VCC on two PCB.

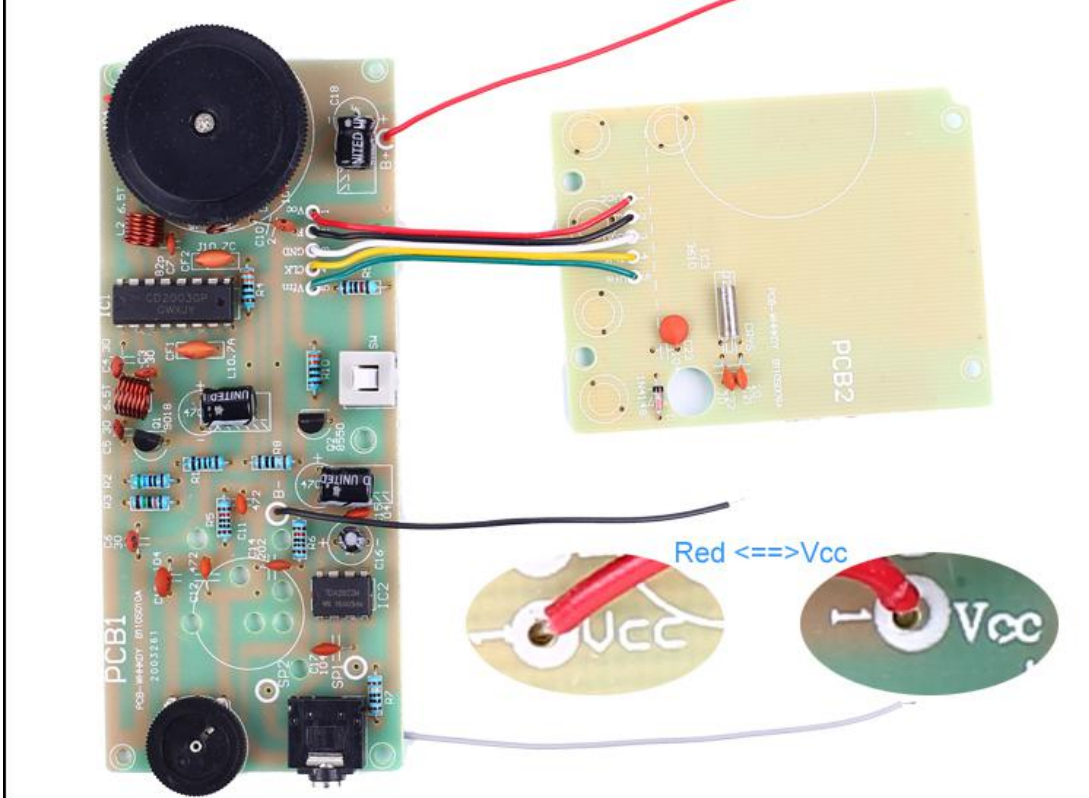



Step 33: Fix 1pcs Antenna with 1pcs Metal Sheet by 1pcs M2.5\*5mm Screw.

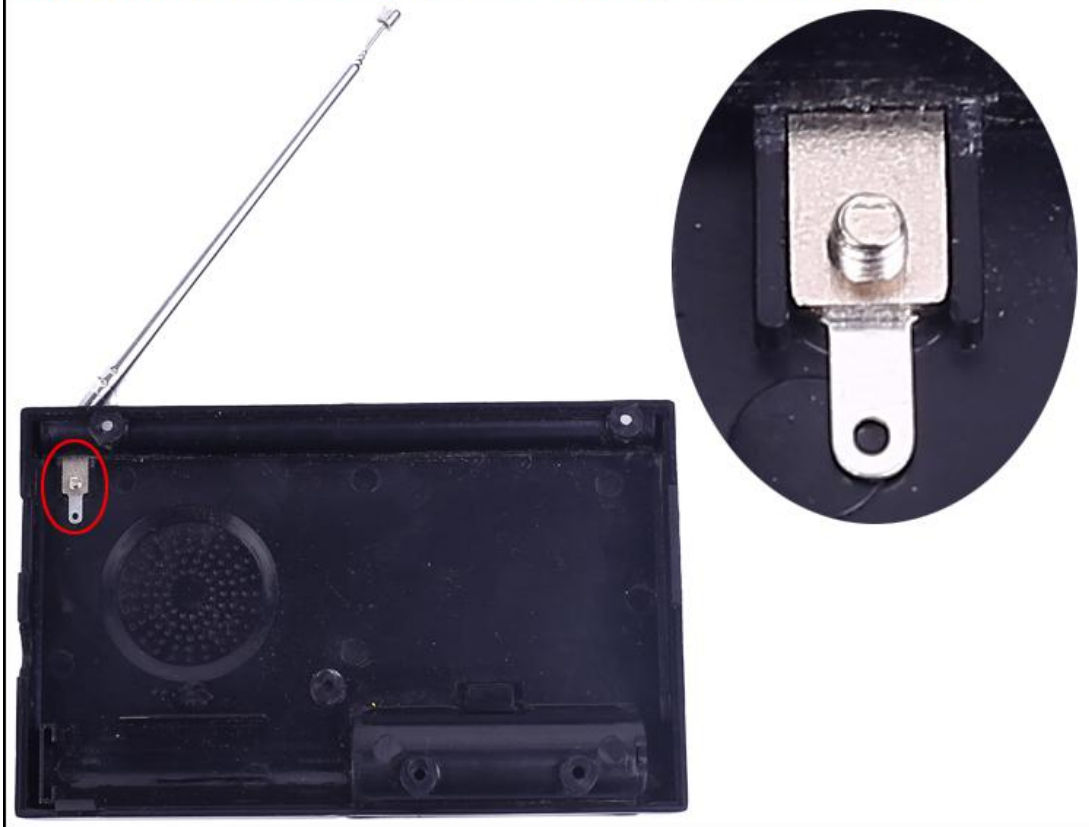

Step 34: Install Battery Positive/Negative Metal Sheet on Case. Pay attention to their installation position.



Step 35: Connect 1pcs D57mm 8ohm 0.5W Speaker to SP1 and SP2 on Main PCB by 2pcs 60mm Wire. The speakers does not need to distinguish between positive and negative poles.

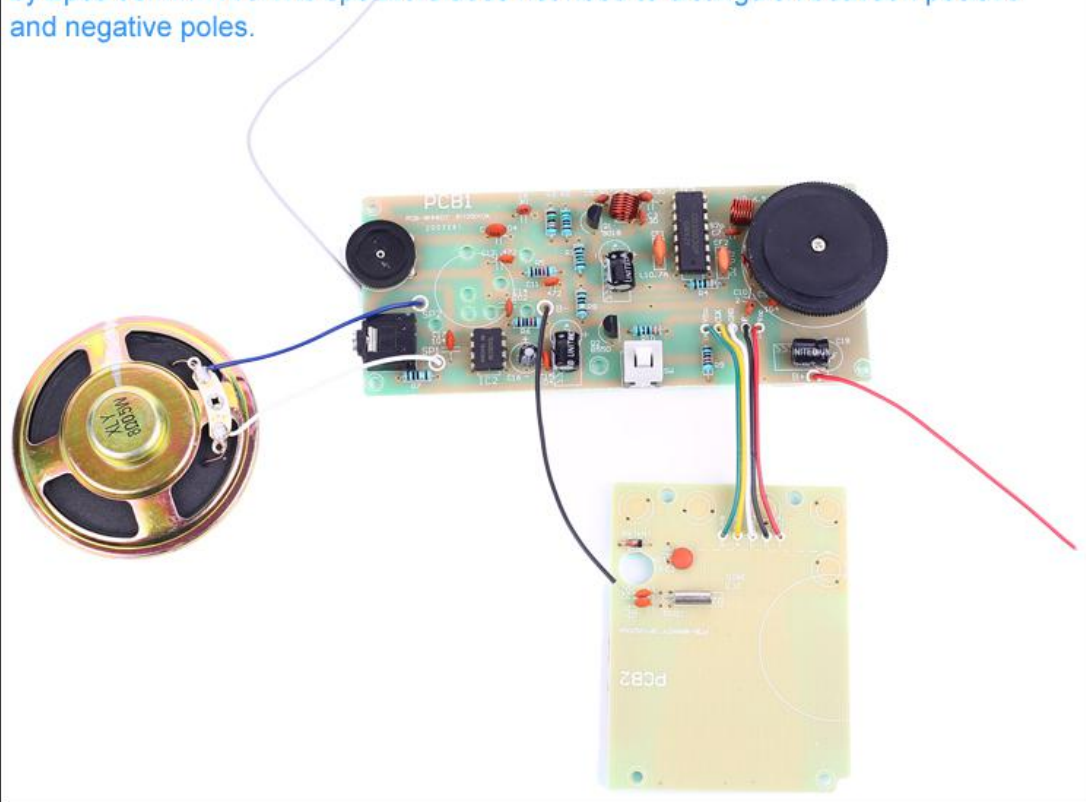

Step 36: Install 1pcs Black Button Cap on Self-locking Switch.



Step 37: Connect 120mm Gray Antenna Wire to Antenna Metal Sheet.



Step 38: Connect 80mm Red wire to Positive Metal Sheet and connect 80mm Black wire to Negative Metal Sheet(with Spring).

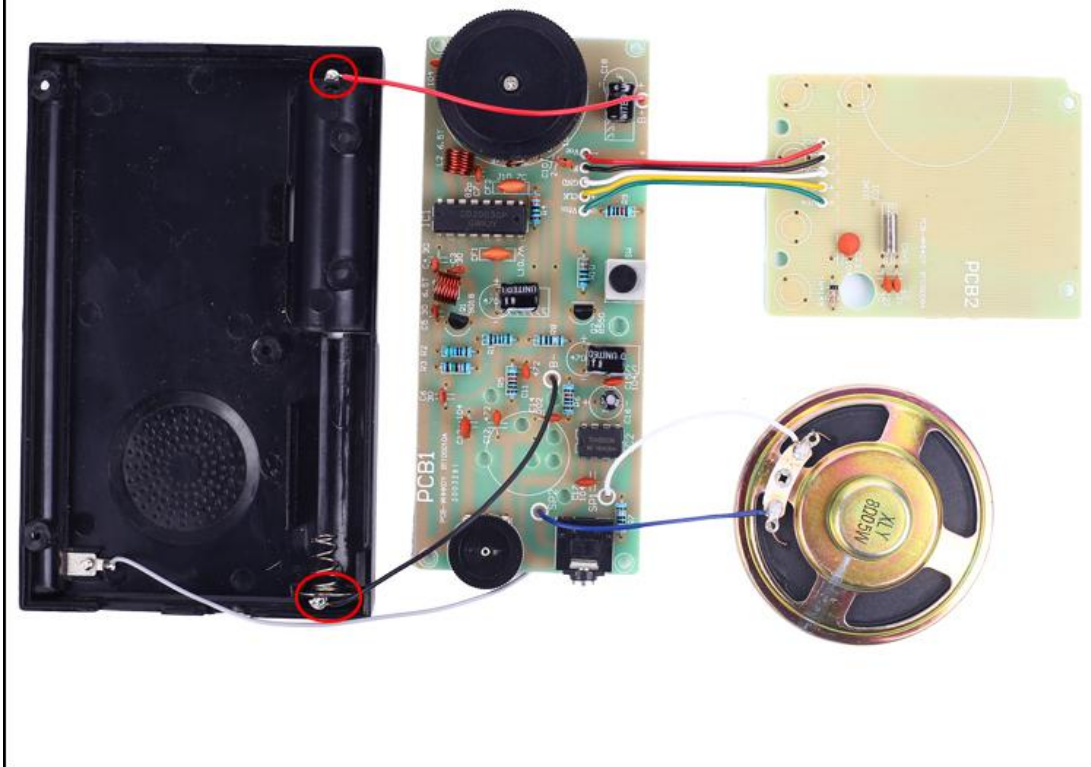

**Step 39: Debugging frequency range.**

- 39.1>.Install 2pcs AA battery(Not include).
- 39.2>.Counterclockwise rotation frequency regulator(Audio Adjust Gear on CMB444HE Capacitor) to so that the display shows the minimum frequency.
- 39.3>.Adjust the distance between the coils on 5.5T Coil Inductor on L1 if the LCD does not display 87MHz to make sure the LCD display 87MHz.
- 39.4>.Clockwise rotation frequency regulator(Audio Adjust Gear on CMB444HE Capacitor) to so that the display shows the maximum frequency.
- 39.5>.Adjust the potentiometer on C1-1 if the LCD does not display 108.6MHz to make sure the LCD display 108.6MHz.
- 39.6>.Adjust these two parameters repeatedly to make the final frequency range is 87MHz~108.6MHz.
- 39.7>.In case of noise, the L1 5.5T coil can be sealed with paraffin or hot melt adhesive after adjustment.
- 39.8>.The campus broadcast frequency range is 72MHz~92MHz.
- 39.9>.The frequency range of aviation frequency band is a 110MHz~130MHz (Note: It requires L1 5.5T to reduce one coil).
- 39.10>.It is recommended that frequency setting range should not exceed 20MHz.

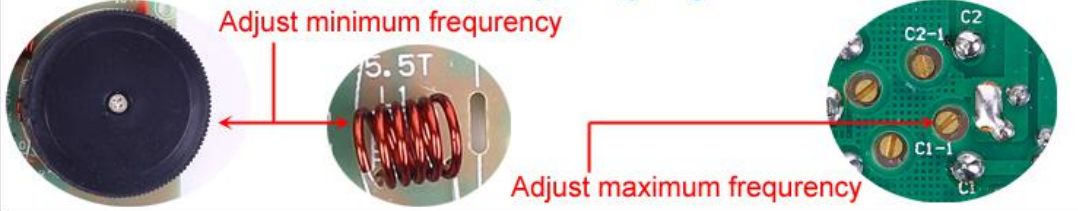

**Step 40: Cut one black button from Black Button Set as shown. Don't be wrong!**

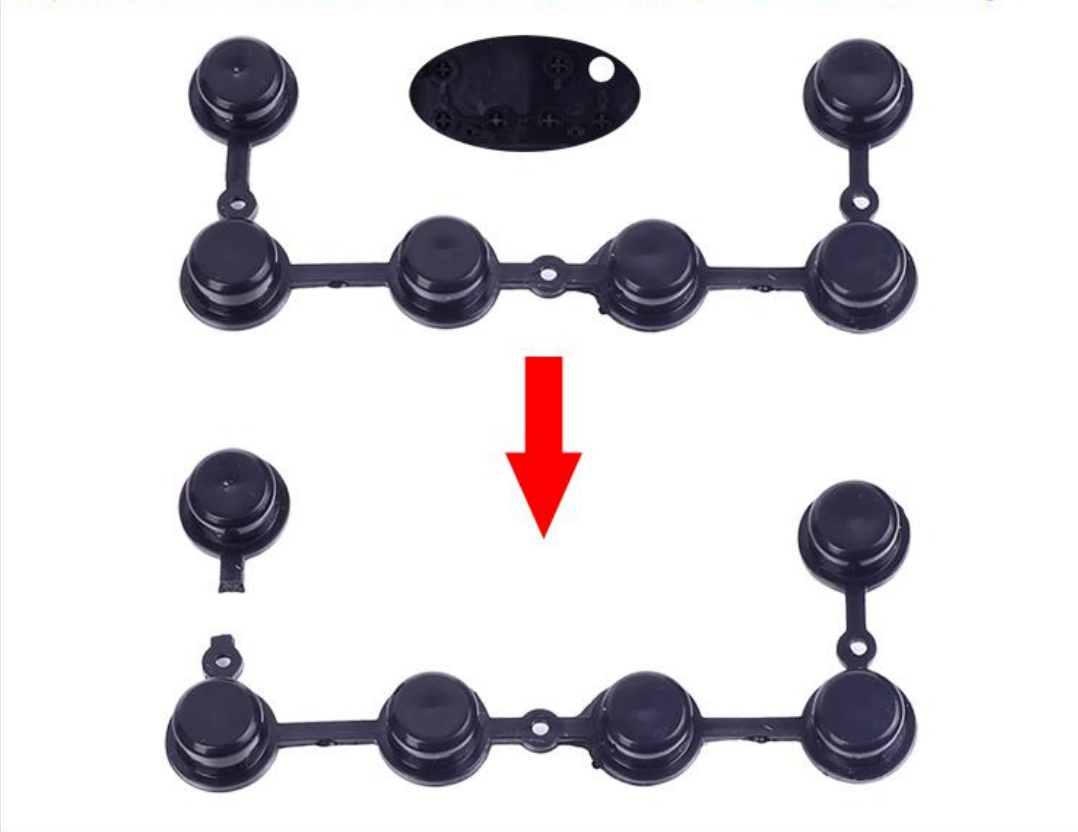

Step 41: The black button position is shown in the figure.

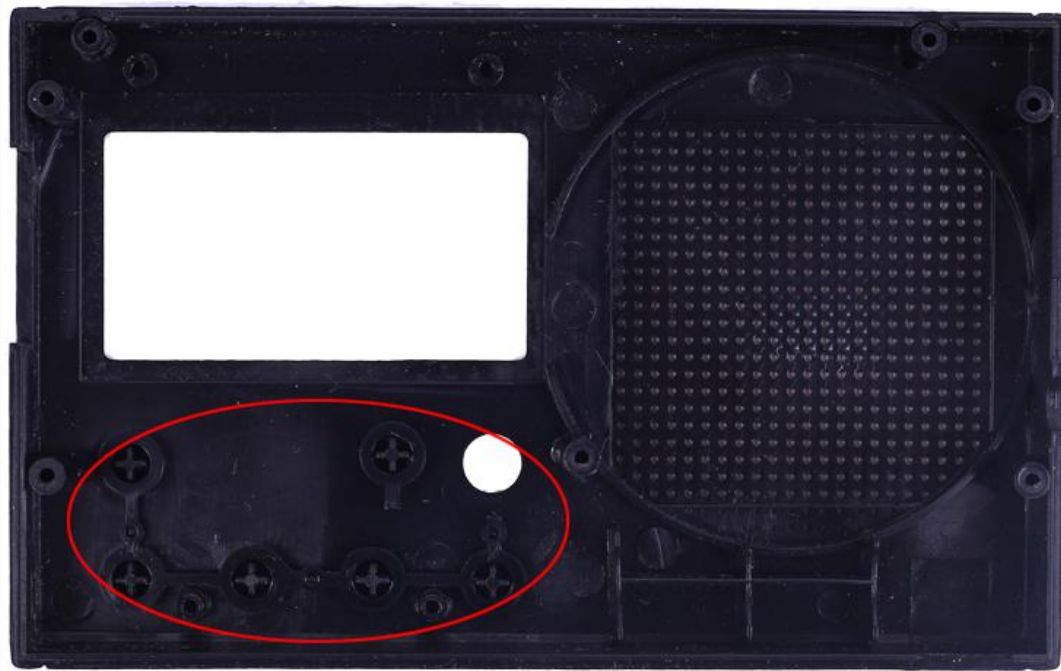

Step 42: Fix LCD Display Module by 2pcs M2\*5mm Screw. Note: The other two holes are not fixed for the time being.

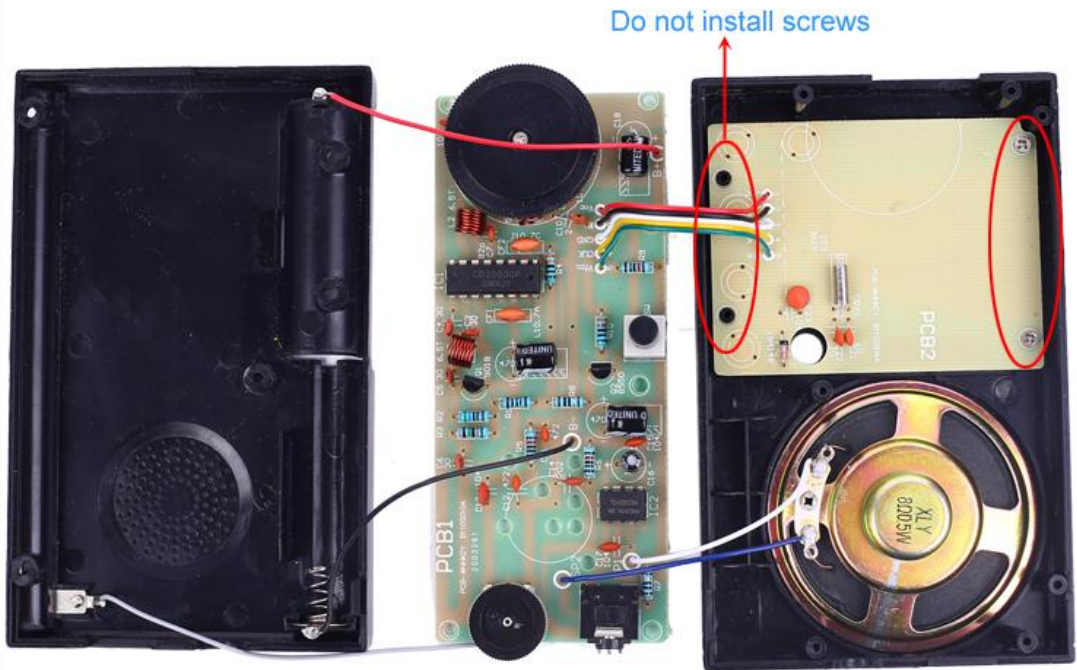

Step 43: Sometimes user need to re-install the black power wire in order to install PCB conveniently.

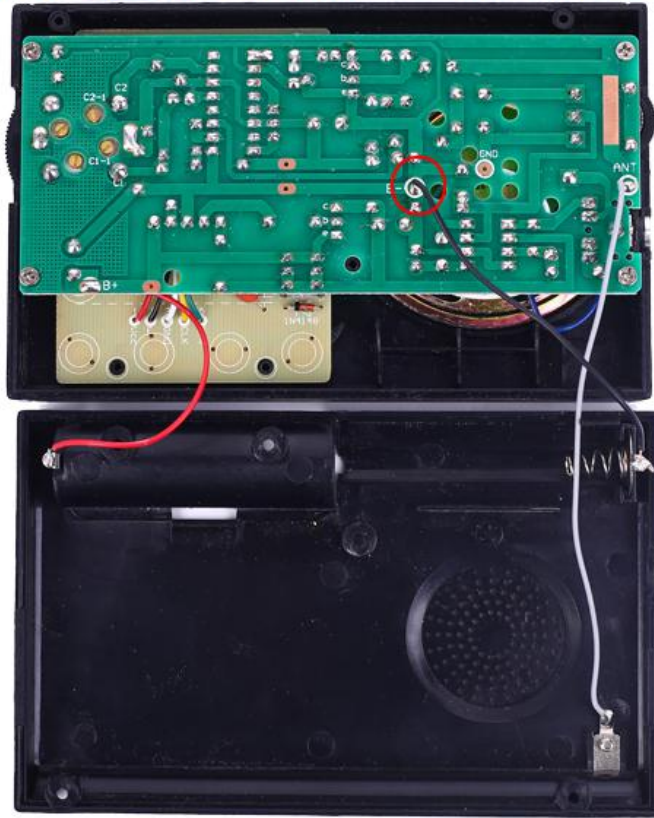

Step 44: Fix two case by 1pcs M2\*8mm Screw and 4pcs M2\*5mm Screw.



Step 45: Install 2pcs AA battery to check whether it can play normally(Users need to prepare batteries by yourself).If there is a fault, it is recommended to check whether each component is installed correctly and whether the pad has false soldering and so on.Please contact us if you have any other questions.

